

Indonesian Crane

Design: William Gozali

Date: 2021-11-05

Difficulty: Intermediate

Paper: 15 cm, 70 gsm

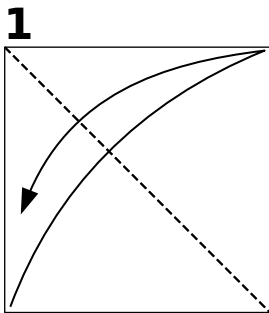
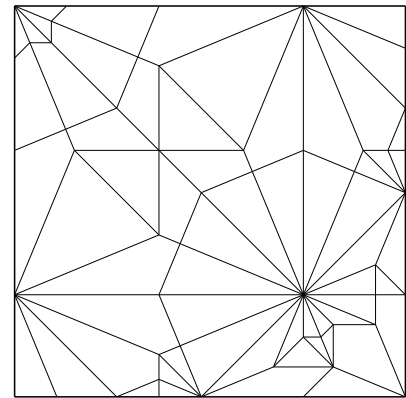
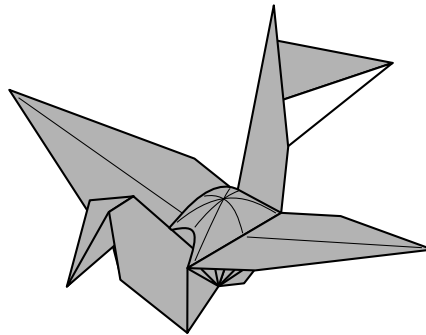

Fold and unfold.

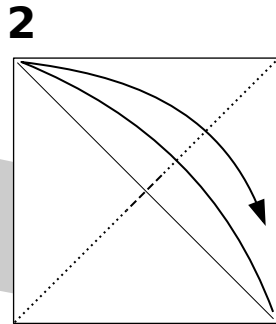

Fold and unfold.
Only crease the
dashed part.

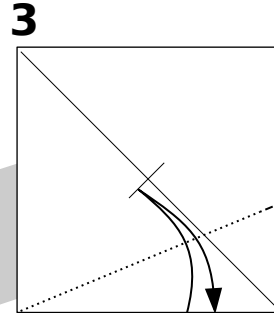

Pinch the edge.

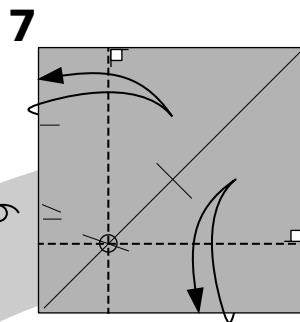
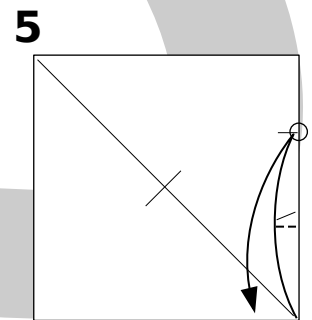
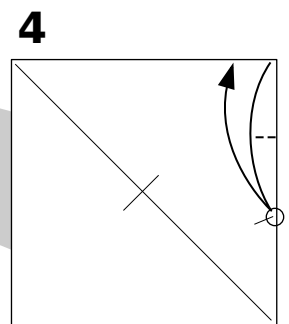

Fold and unfold at
referenced point
perpendicular to the
paper's edge.

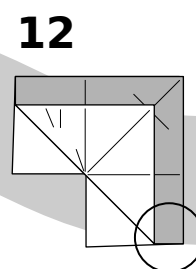
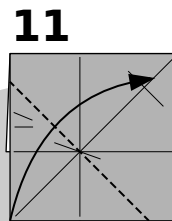
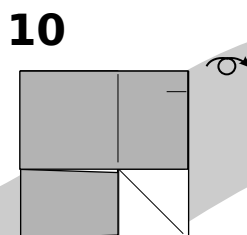
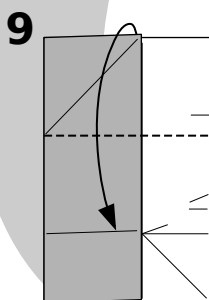
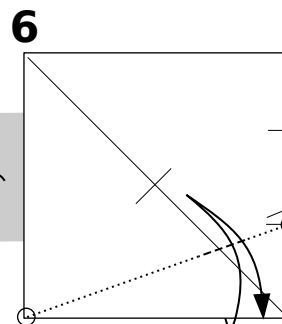
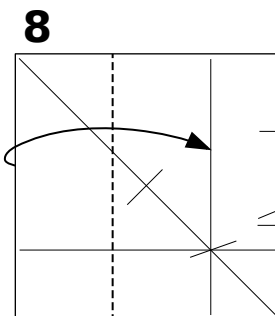

Fold and unfold
through all layers.

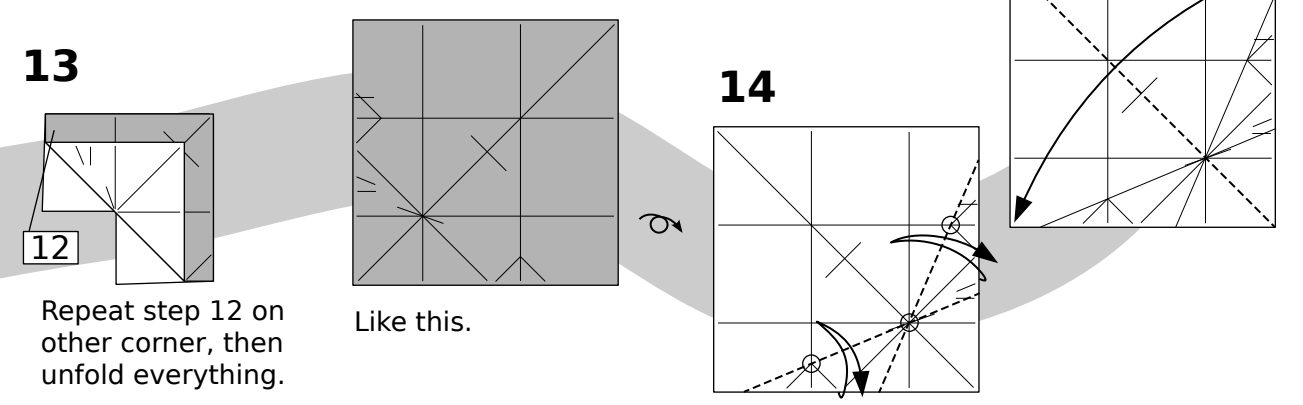
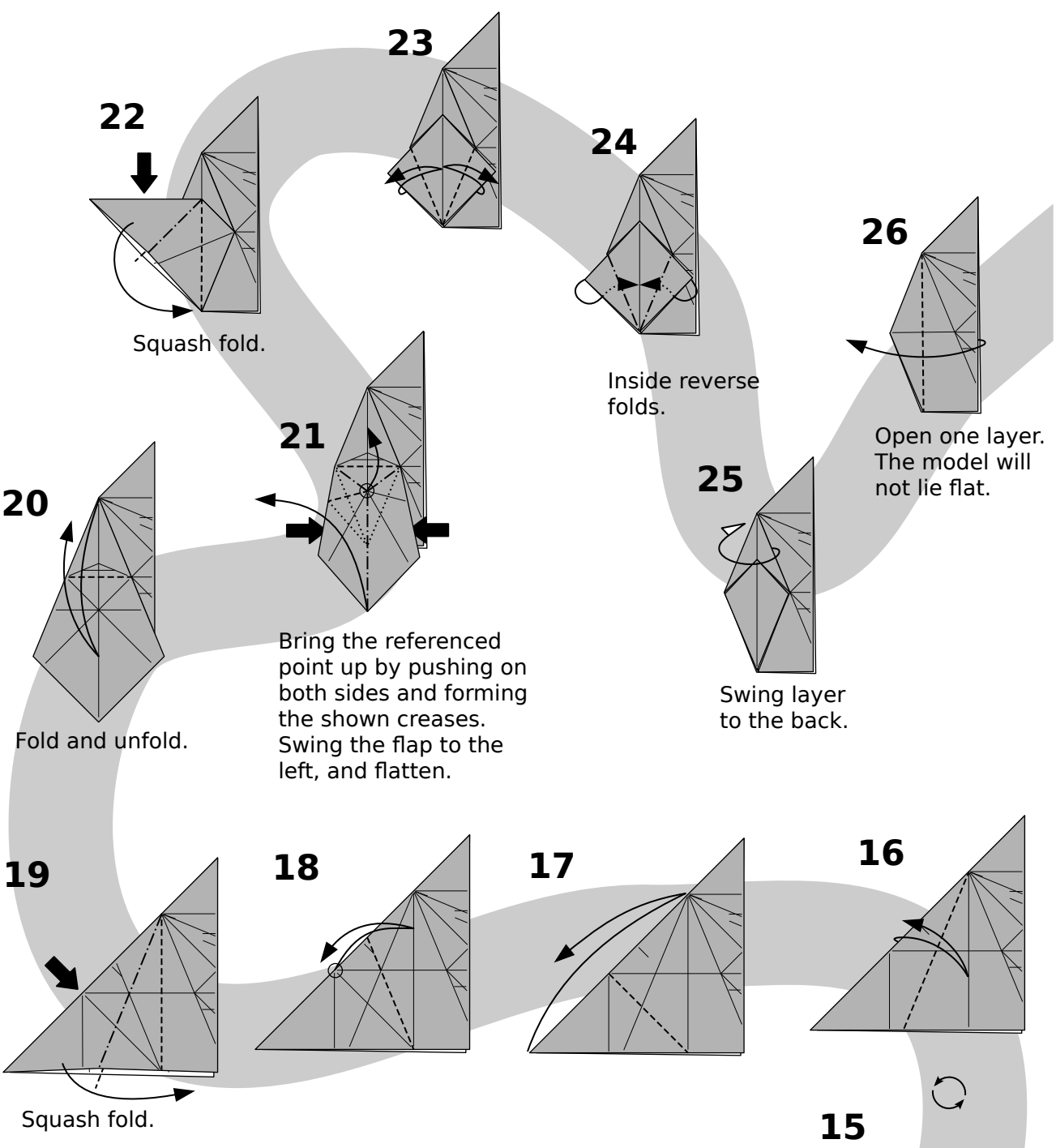

12 Repeat step 12 on other corner, then unfold everything.

13 Like this.

14

15

16

17

18

19 Squash fold.

20

21 Bring the referenced point up by pushing on both sides and forming the shown creases. Swing the flap to the left, and flatten.

22 Squash fold.

23 Inside reverse folds.

24 Inside reverse folds.

25 Swing layer to the back.

26 Open one layer. The model will not lie flat.

27

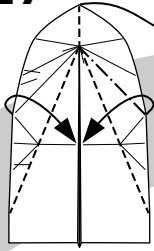

Flatten by making shown creases and swing the top flap to the right.

28

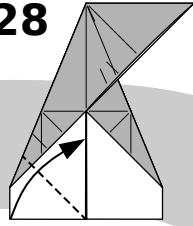

29

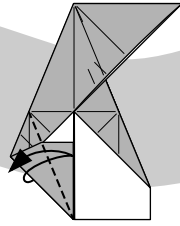

Fold and unfold. Undo step 28.

30

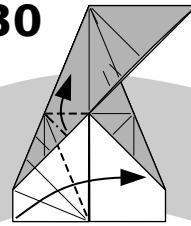

Swivel fold.

31

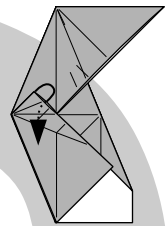

Inside reverse fold to tuck the paper underneath.

35

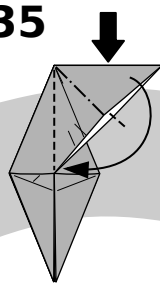

Squash fold.

34

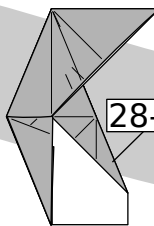

Repeat on other side.

33

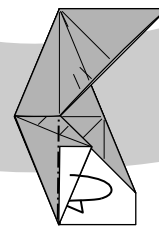

Insert into the pocket.

32

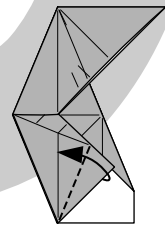

36

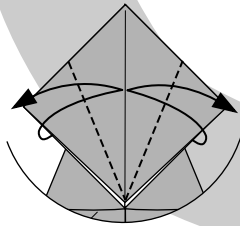
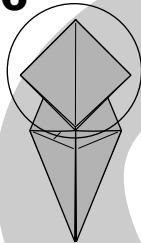

37

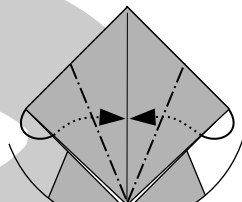

Inside reverse folds.

41

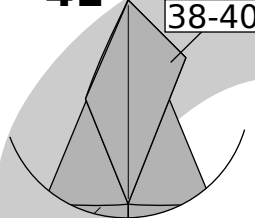

Repeat on other side.

42

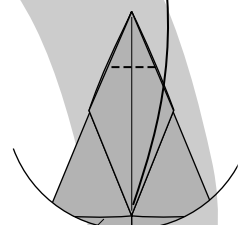

Open all the way up and stretch.

38

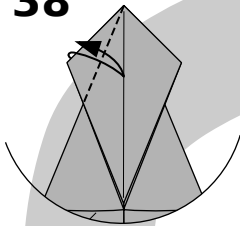

39

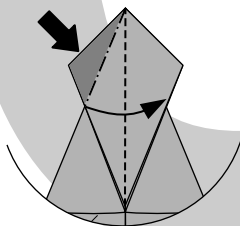

Spread squash.

40

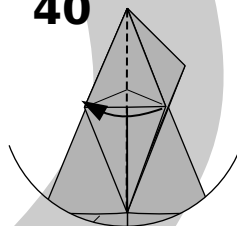

Like this.

43

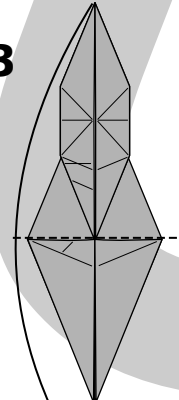

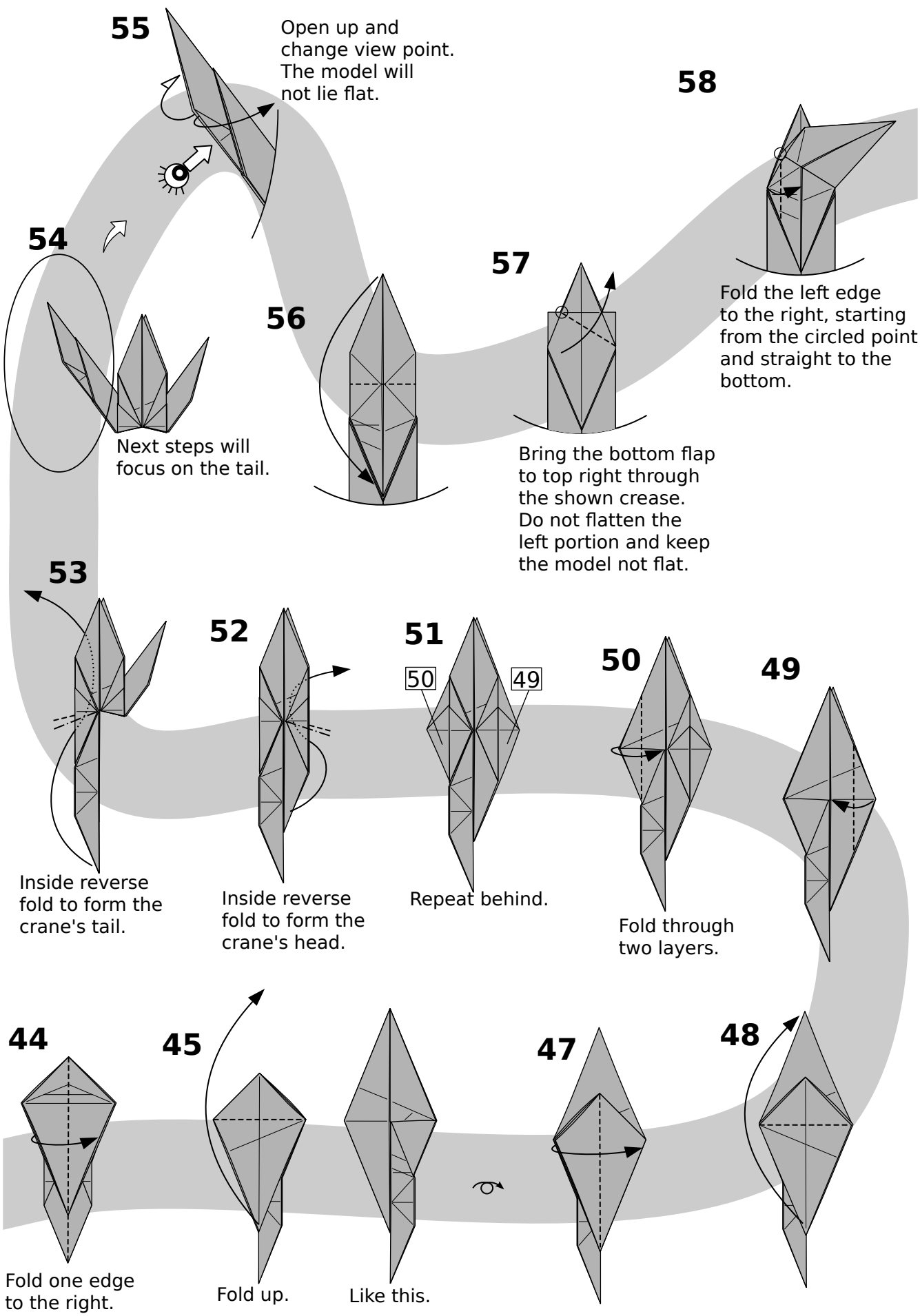

55

Open up and change view point. The model will not lie flat.

58

Fold the left edge to the right, starting from the circled point and straight to the bottom.

54

Next steps will focus on the tail.

57

Bring the bottom flap to top right through the shown crease. Do not flatten the left portion and keep the model not flat.

56

53

Inside reverse fold to form the crane's tail.

52

Inside reverse fold to form the crane's head.

51

Repeat behind.

50

Fold through two layers.

49

44

Fold one edge to the right.

45

Fold up.

Like this.

47

48

59

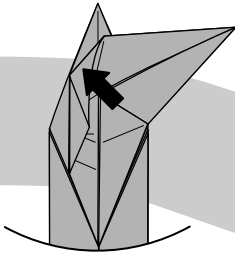

Push the top left to flatten the model.

60

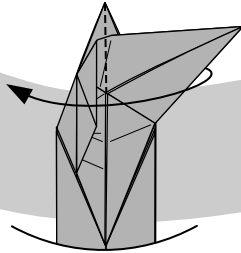

Swing one layer to the left.

61

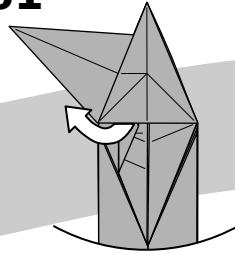

Pull out the paper underneath the top layer. The model will not lie flat.

62

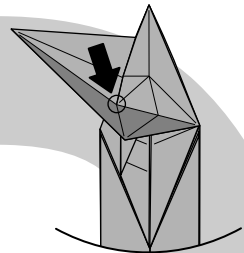

Push the referenced point until sunken.

64

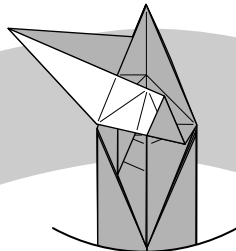

Like this.

63

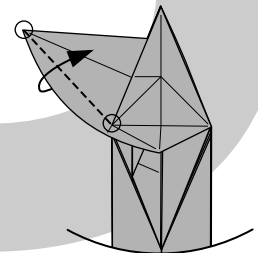

Valley fold along the referenced points. Do not flatten.

65

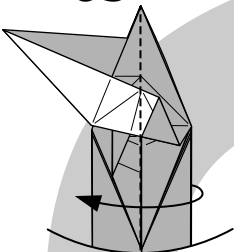

Close the tail.

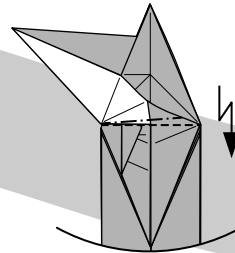

Flatten by forming pleat on the loose paper.

66

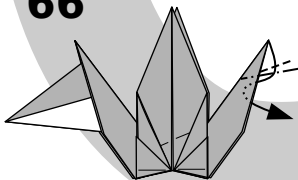

Inside reverse fold.

68

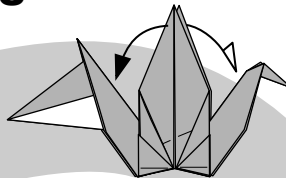

Spread the wings.

69

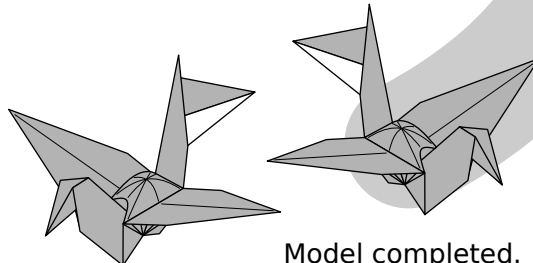

Model completed.