

Pukeko Chick

Model version : 1.1
Diagram version : 2025-06-23
Designer & diagram: William Gozali
Recommended size: 30 cm

Heads-up! This silly model turns out to be harder than I thought. Beginners may need several attempts to successfully fold it. Use thin and strong paper. A4 printing or standard origami paper will unlikely yield good result. Glue might be required on suboptimal paper to prevent the layers from splaying apart.

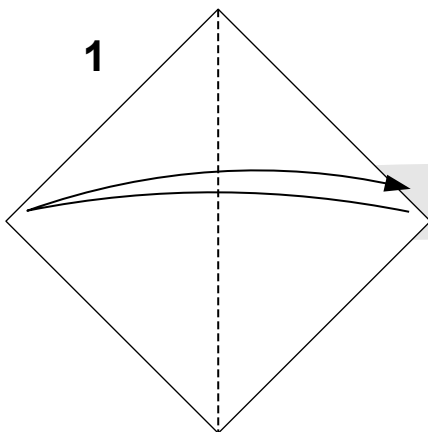
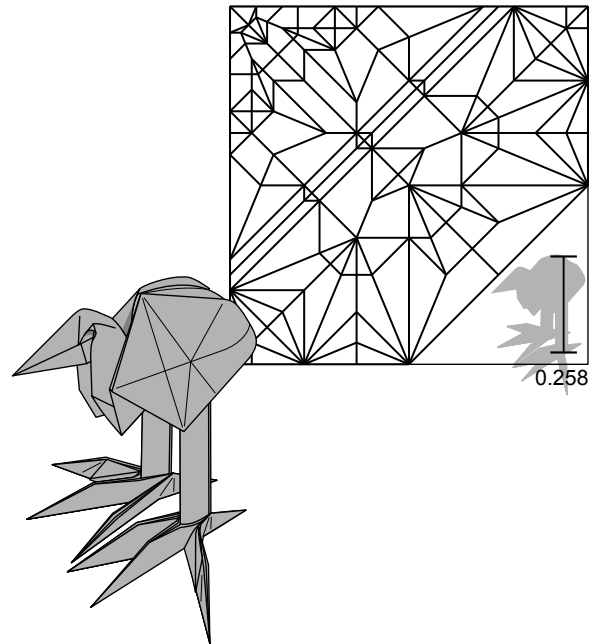

Start with white side up.

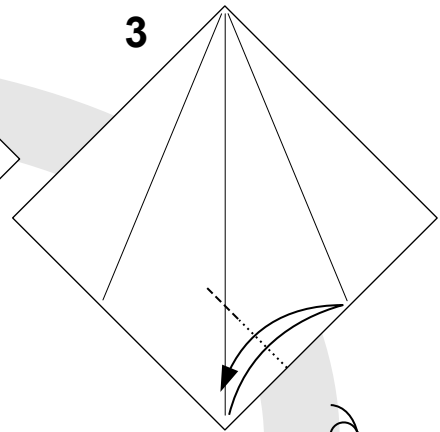
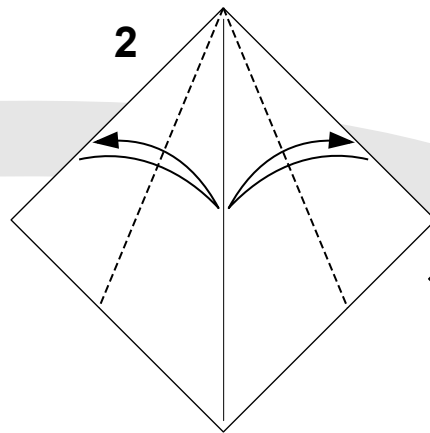

Make a pinch.

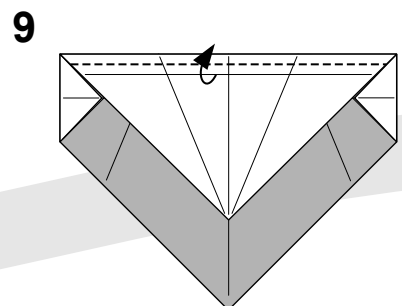
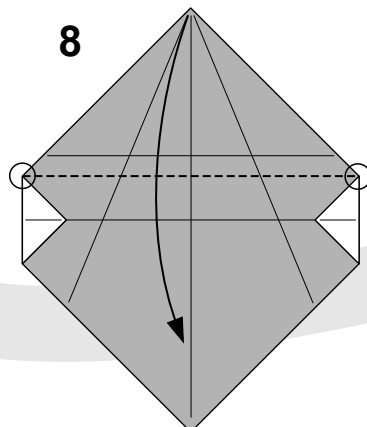
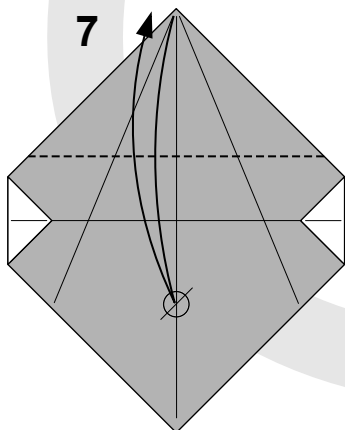
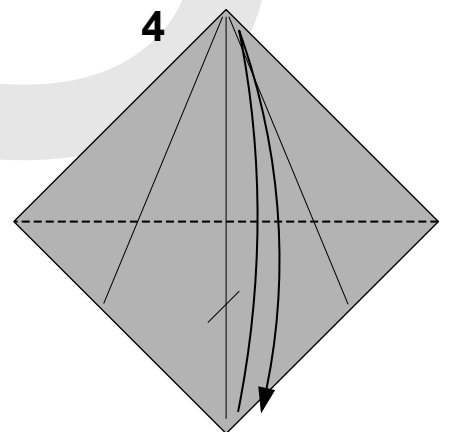
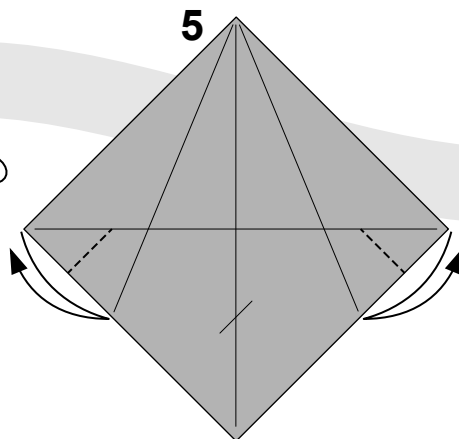
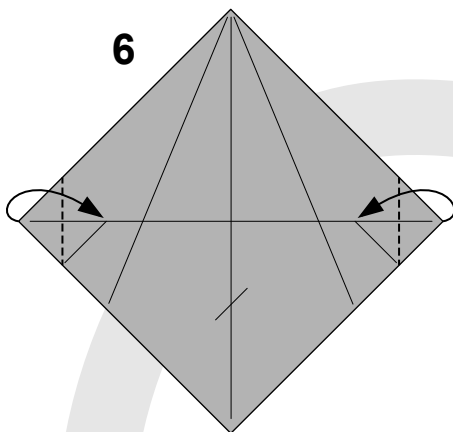

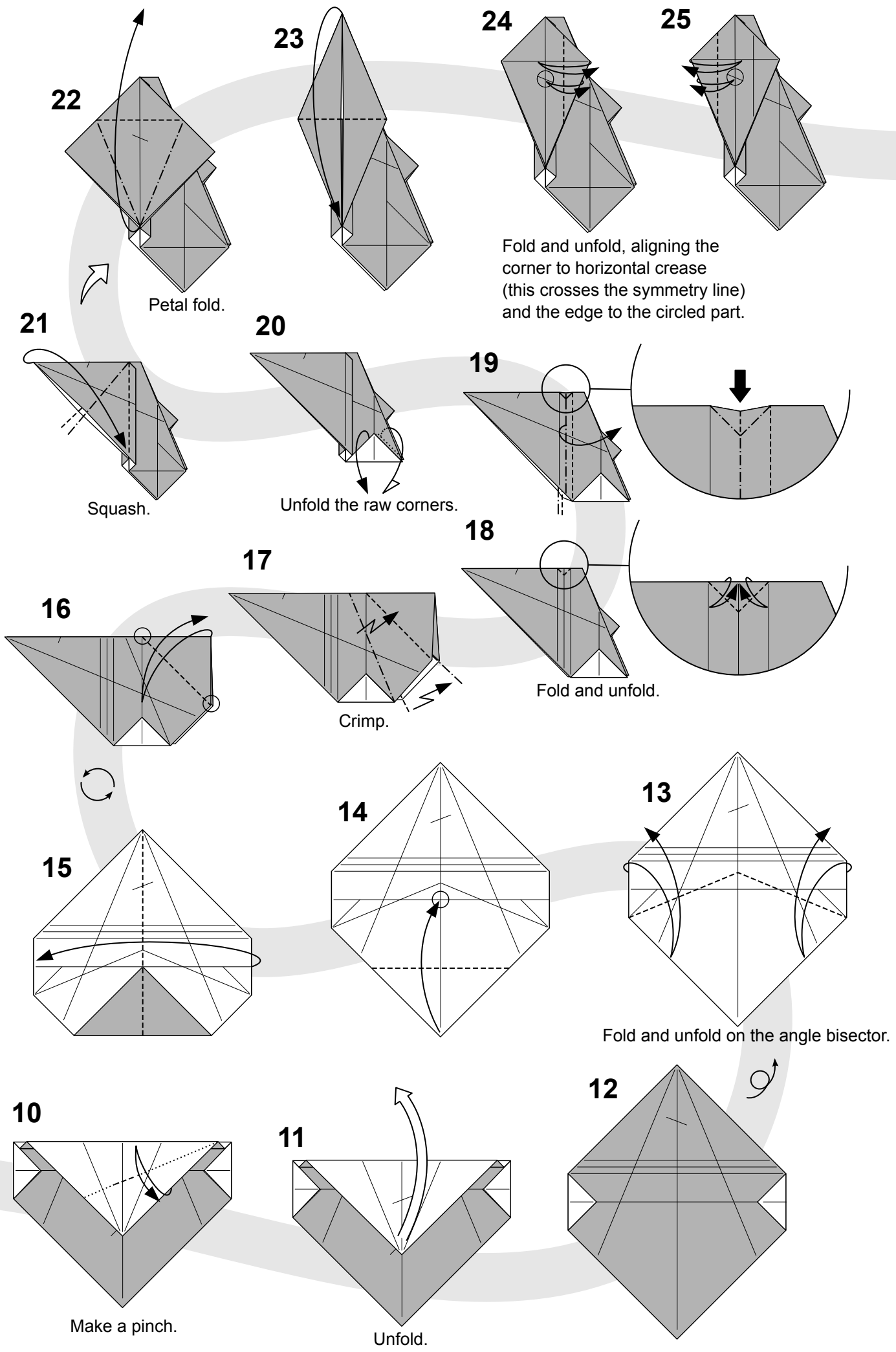

10

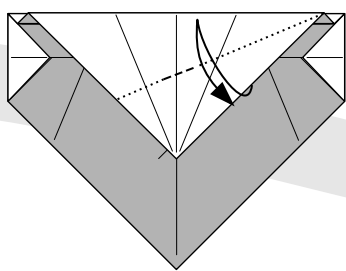

Make a pinch.

11

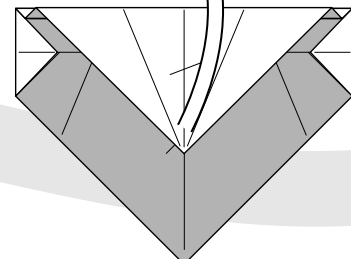

Unfold.

12

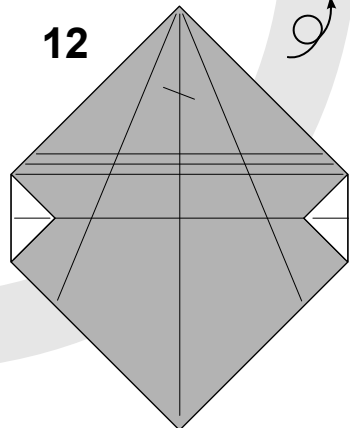

Fold and unfold on the angle bisector.

13

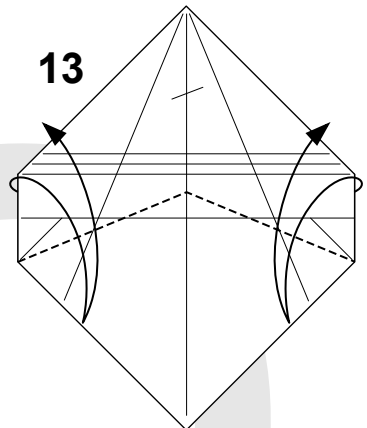

14

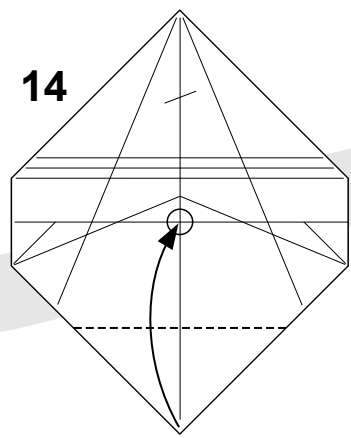

15

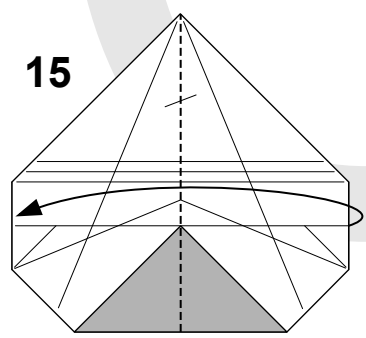

17

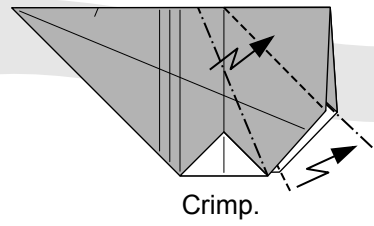

Crimp.

18

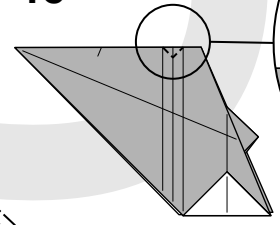

Fold and unfold.

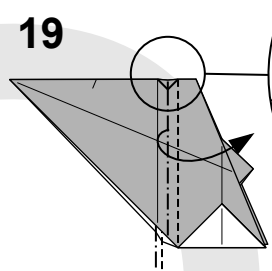
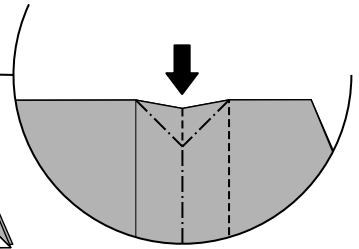

20

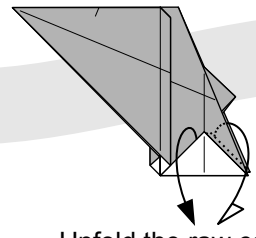

Unfold the raw corners.

Squash.

21

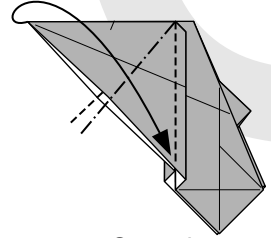

Petal fold.

22

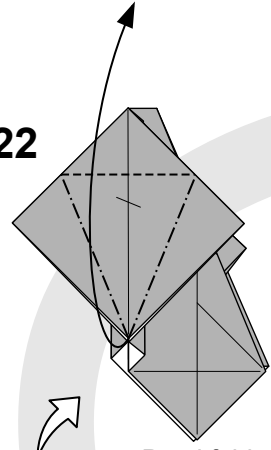

24

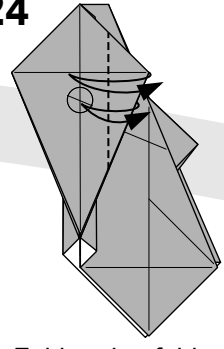

25

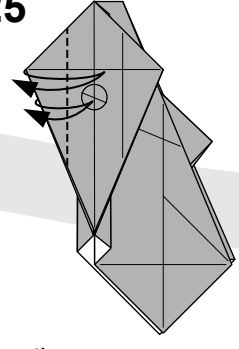

Fold and unfold, aligning the corner to horizontal crease (this crosses the symmetry line) and the edge to the circled part.

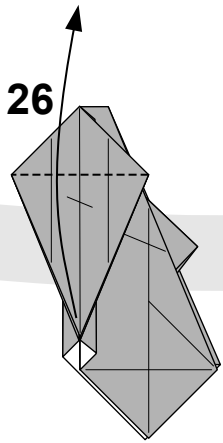

26

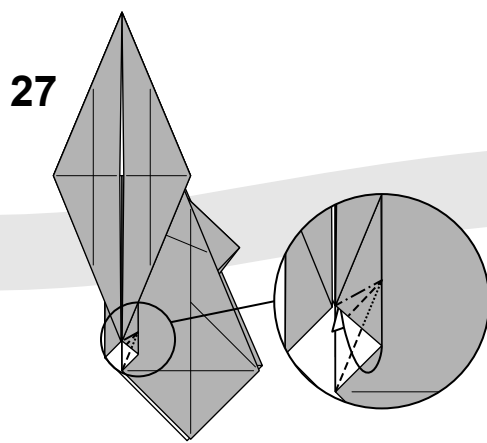

27

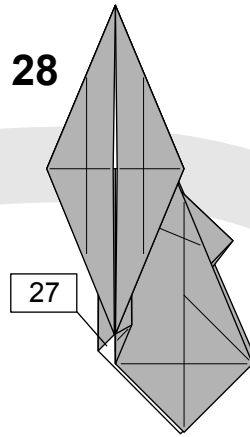

28

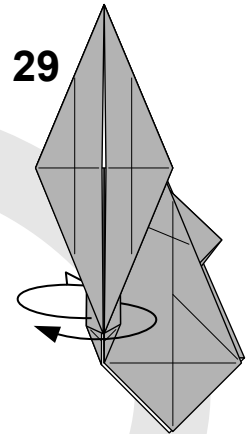

29

Swing 2 layers.

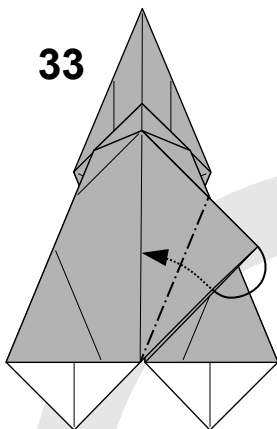

33

Inside reverse fold.

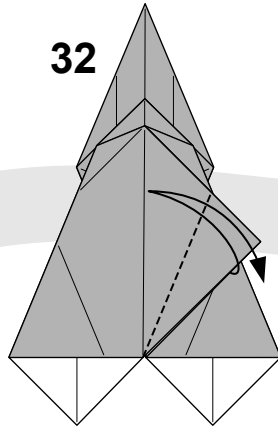

32

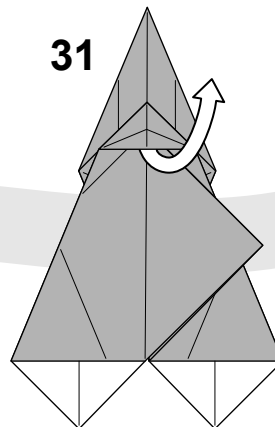

31

Bring the hidden corner outside.

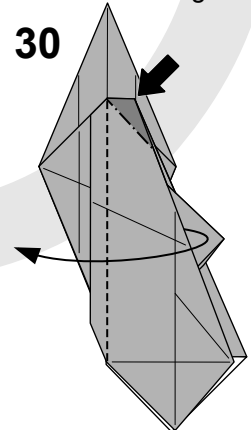

30

Spread squash.

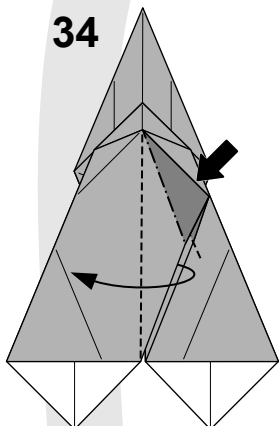

34

Spread squash.

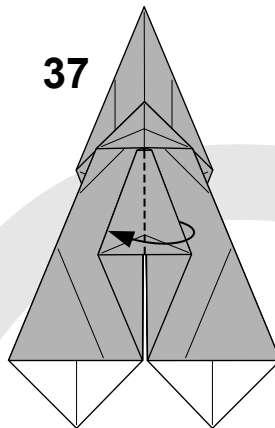

37

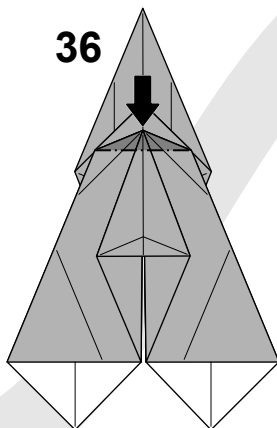

36

Open sink.

The next 43 steps focus on the right side, and will also be applied on the left side. You may apply the steps on left side along the way.

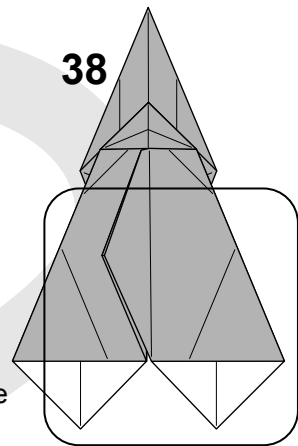

38

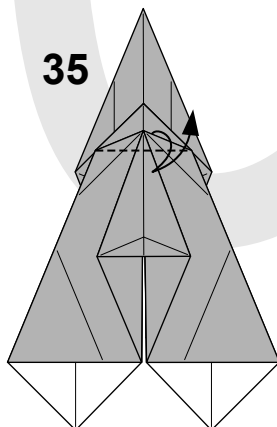

35

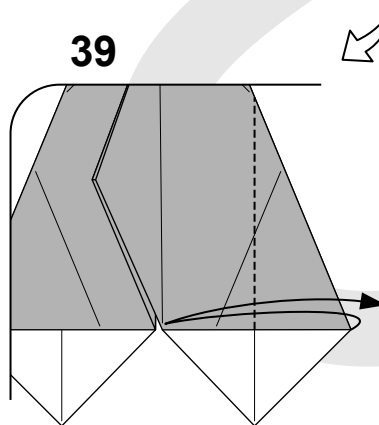

39

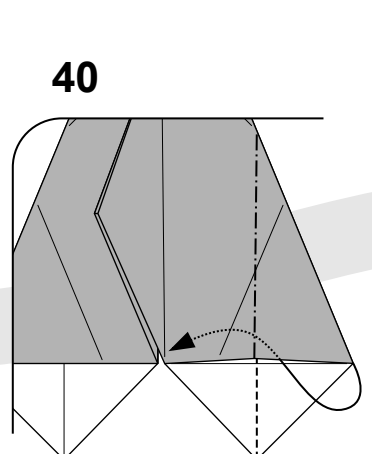

40

Inside reverse fold.

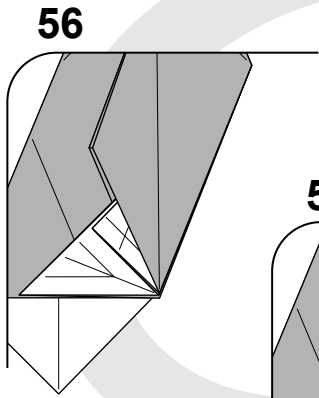

56

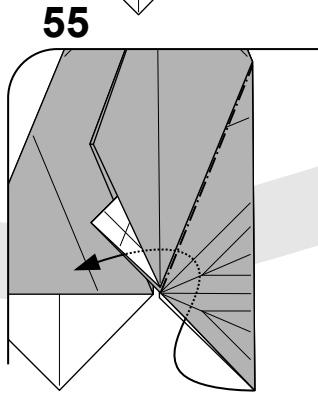

55

Inside reverse fold.

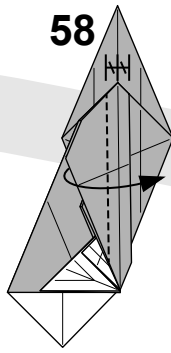

58

Carefully fold the thick edge to the right, keeping the width equal to other side's edge.

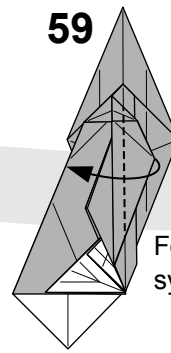

59

Fold along the symmetry line.

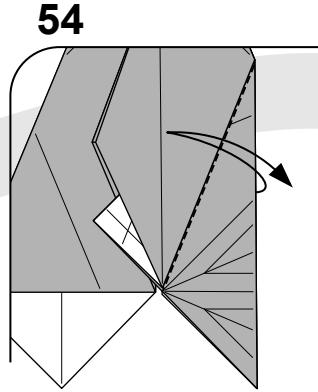

54

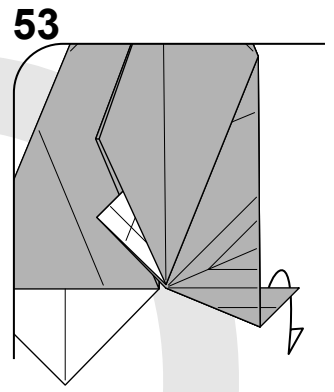

53

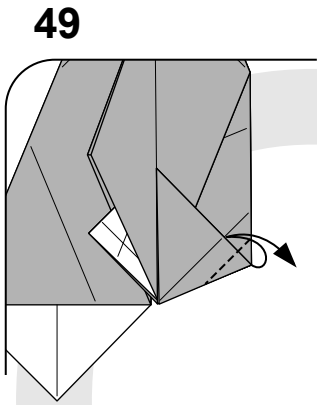

49

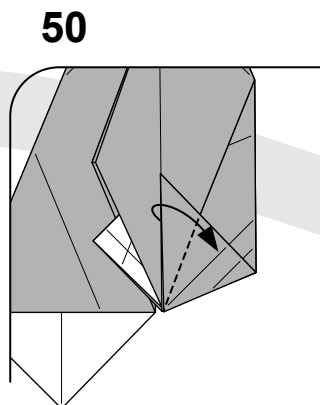

50

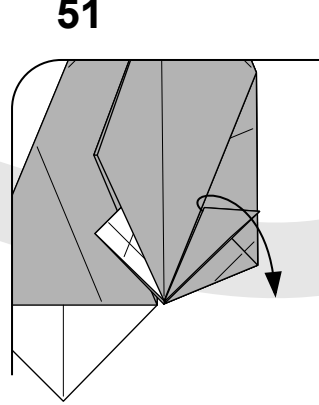

51

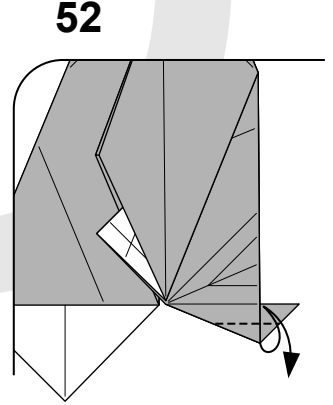

52

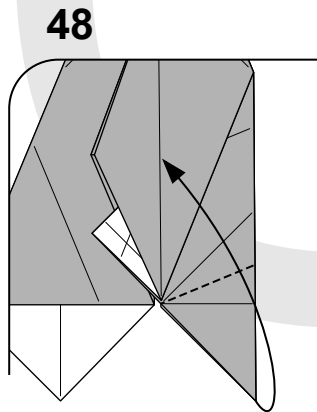

48

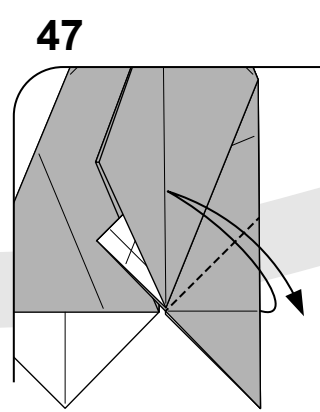

47

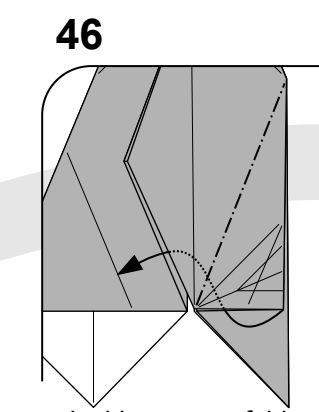

46

Inside reverse fold.

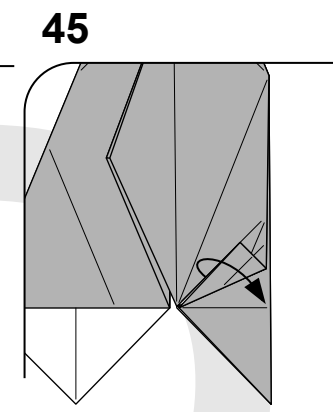

45

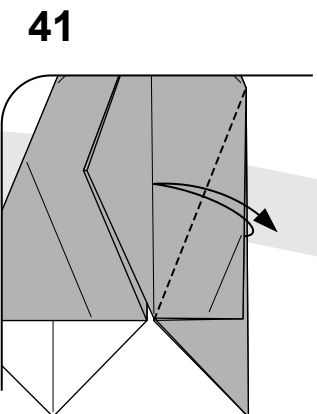

41

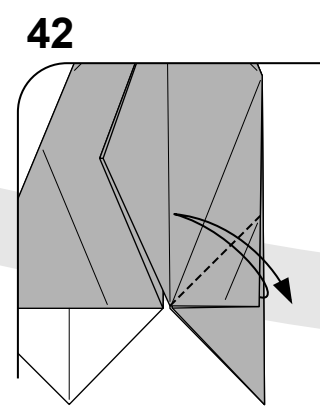

42

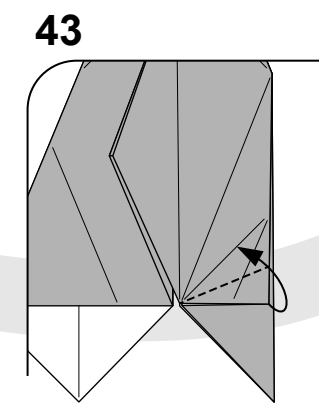

43

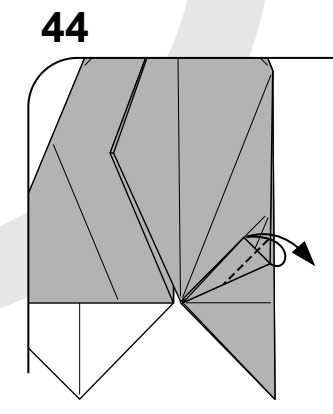

44

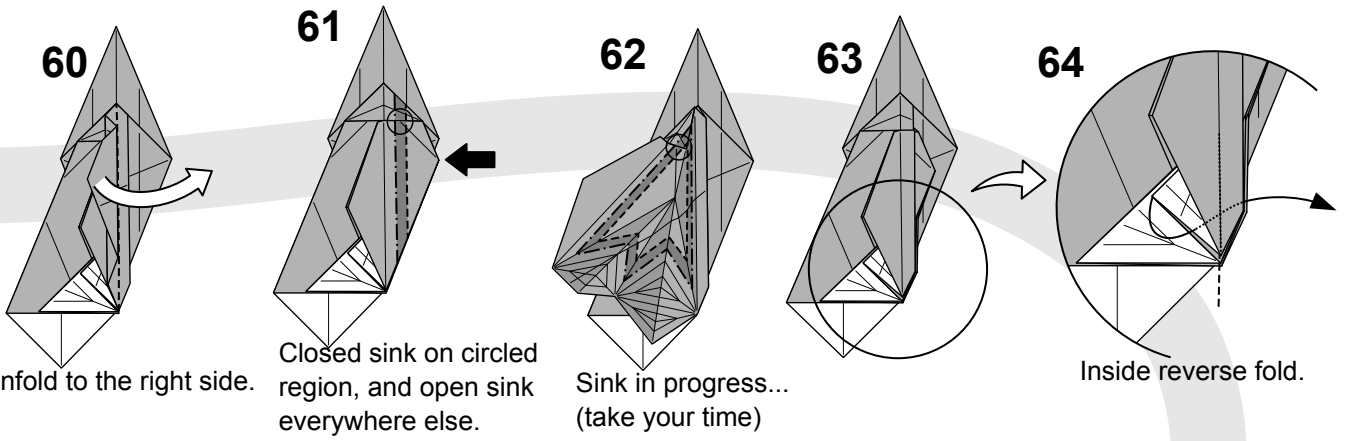

60 Unfold to the right side.

61 Closed sink on circled region, and open sink everywhere else.

62 Sink in progress... (take your time)

64 Inside reverse fold.

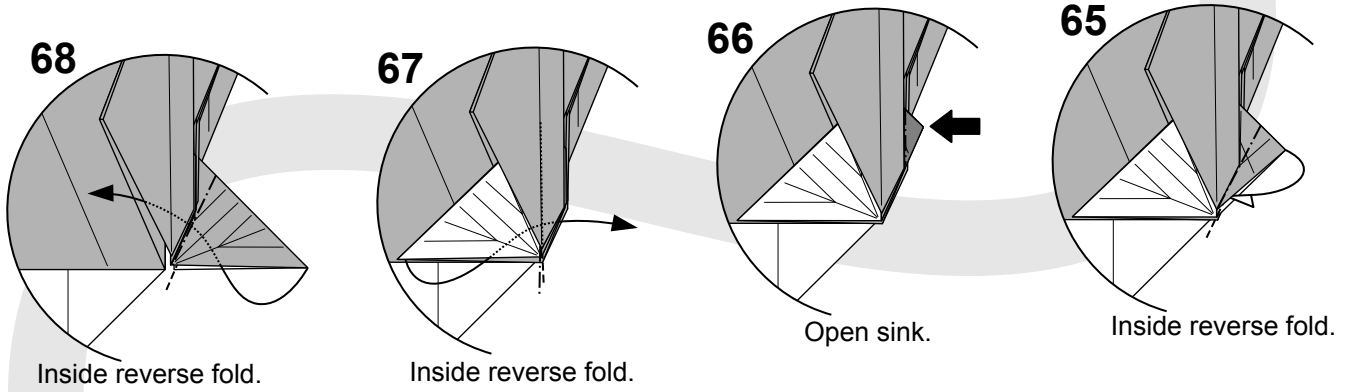

68 Inside reverse fold.

67 Inside reverse fold.

66 Open sink.

65 Inside reverse fold.

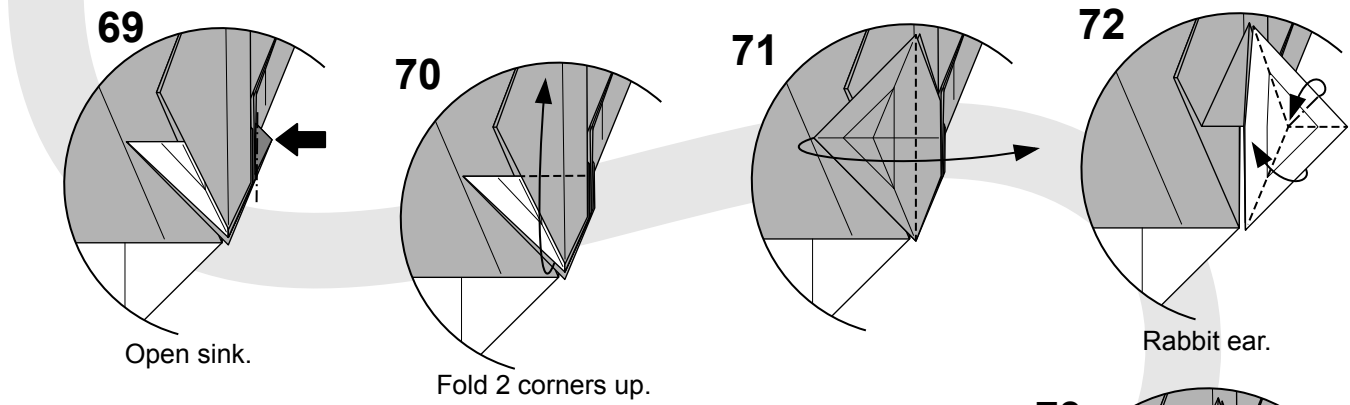

69 Open sink.

70 Fold 2 corners up.

72 Rabbit ear.

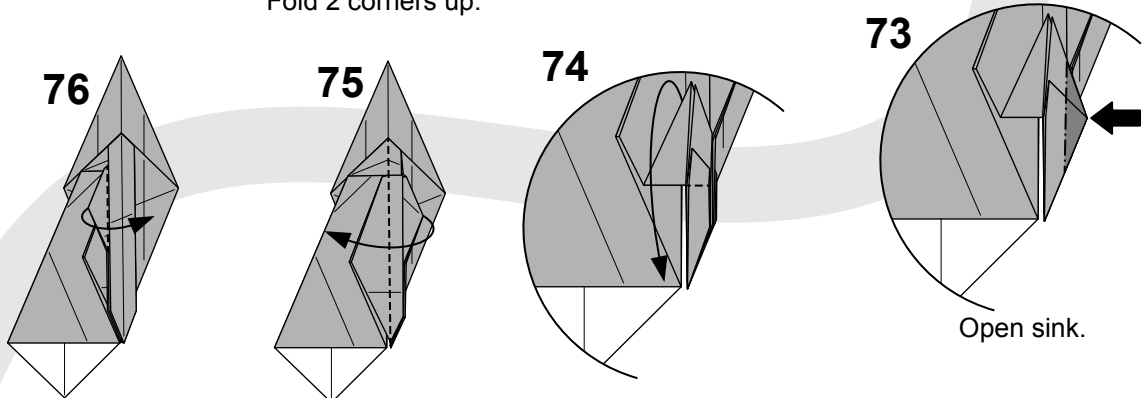

73 Open sink.

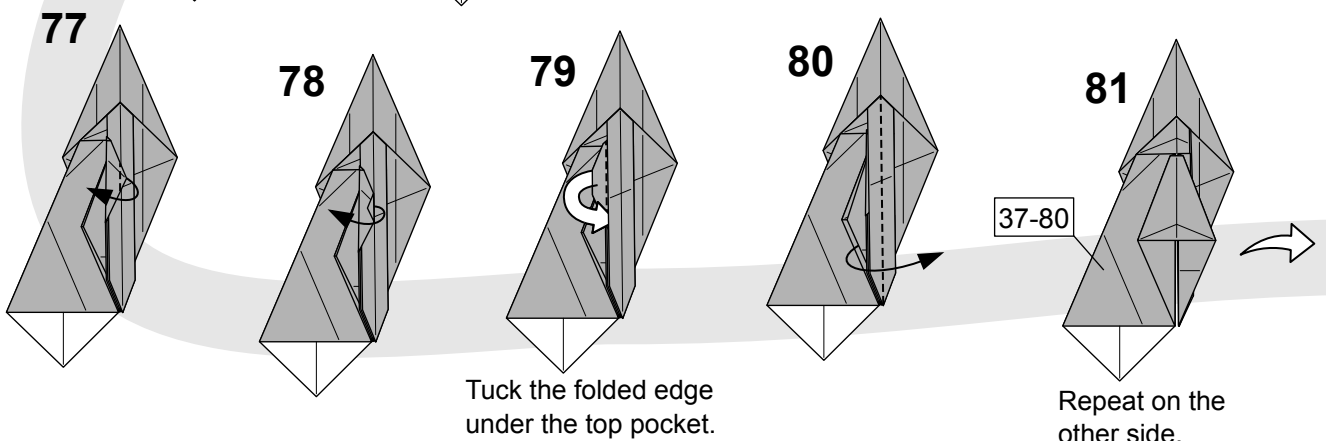

79 Tuck the folded edge under the top pocket.

81 Repeat on the other side.

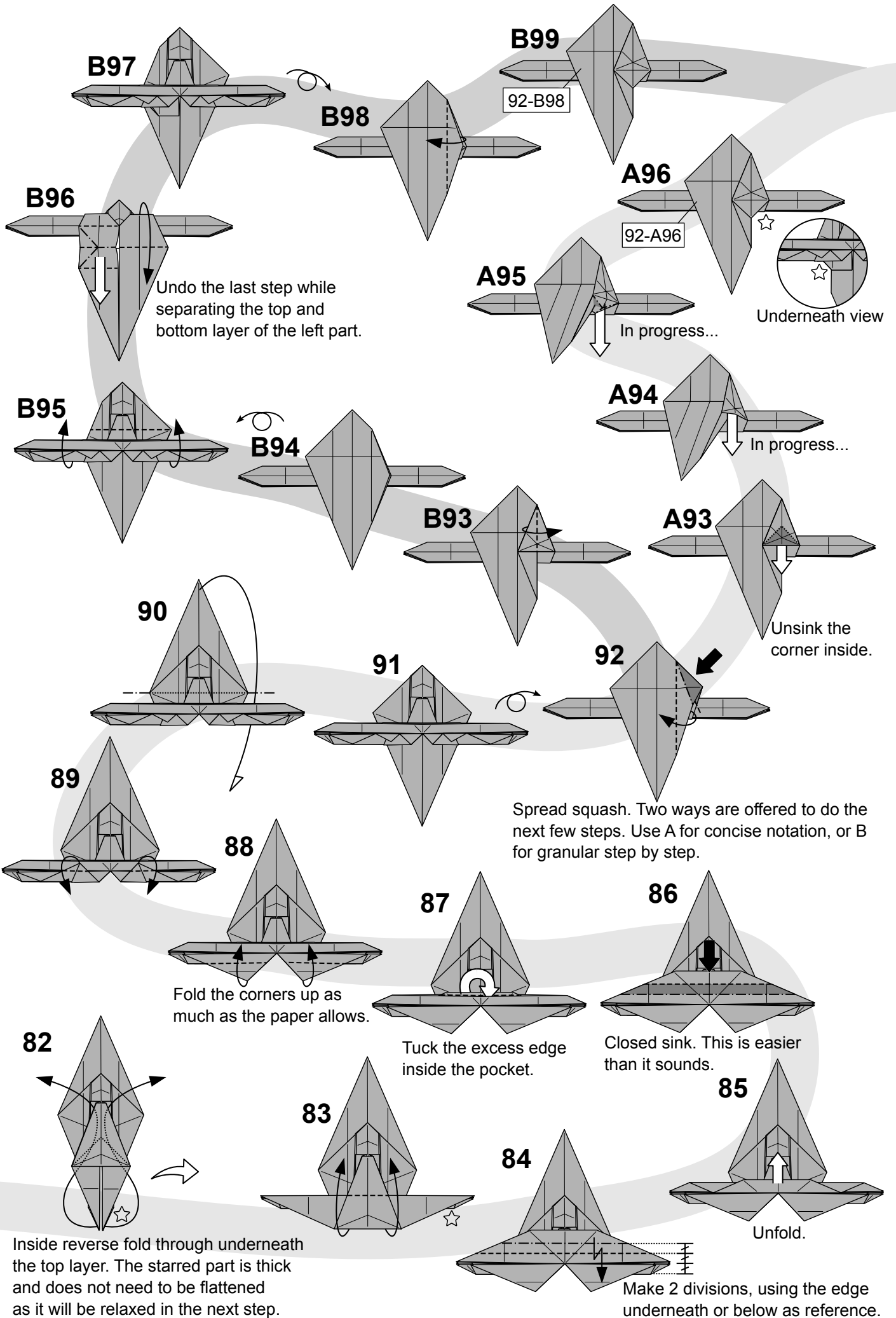

B97

B98

B99

92-B98

A96

92-A96

Underneath view

B96

Undo the last step while separating the top and bottom layer of the left part.

A95

In progress...

B95

B94

A94

In progress...

B93

A93

Unsink the corner inside.

90

91

92

89

Spread squash. Two ways are offered to do the next few steps. Use A for concise notation, or B for granular step by step.

88

87

86

Fold the corners up as much as the paper allows.

Tuck the excess edge inside the pocket.

Closed sink. This is easier than it sounds.

82

83

84

85

Unfold.

Inside reverse fold through underneath the top layer. The starred part is thick and does not need to be flattened as it will be relaxed in the next step.

Make 2 divisions, using the edge underneath or below as reference.

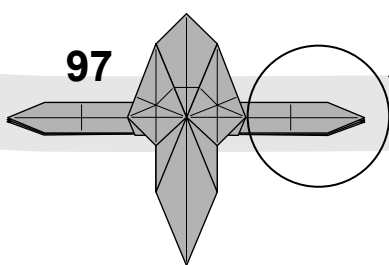

97

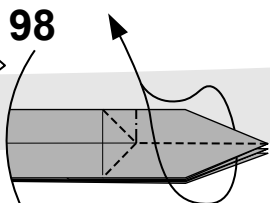

98

Rabbit ear at the base of the top flap.

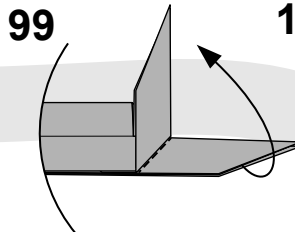

99

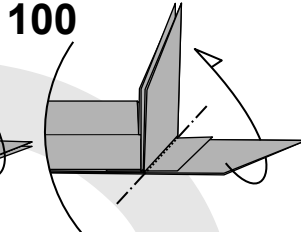

100

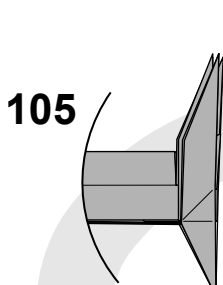

105

This will be the bird's toes.

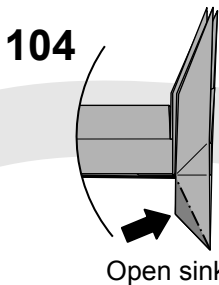

104

Open sink.

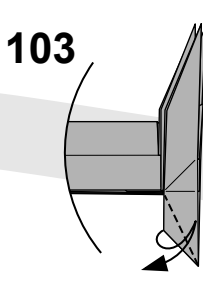

103

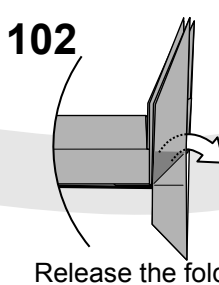

102

Release the folded edge. This makes the layer distribution more even.

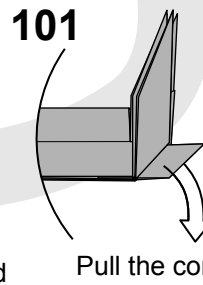

101

Pull the corner.

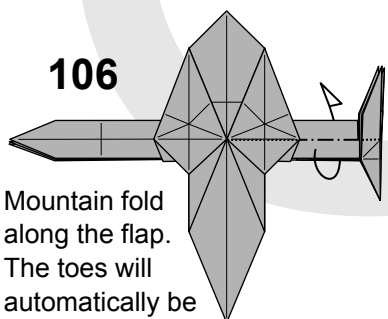

106

Mountain fold along the flap. The toes will automatically be twisted and face the other direction.

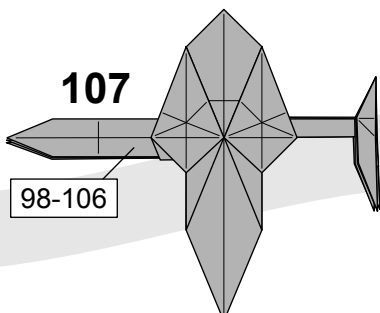

107

98-106

Repeat on the other side. You may apply glue to prevent the layers of the legs from splaying apart/getting unfolded.

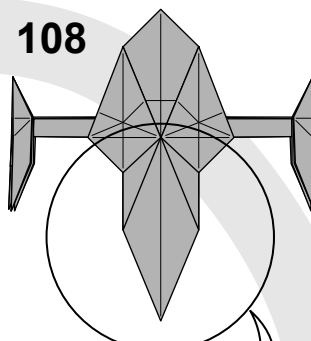

108

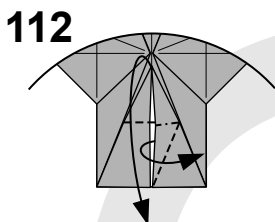

112

Undo the last step while separating the top and bottom layer of the right part.

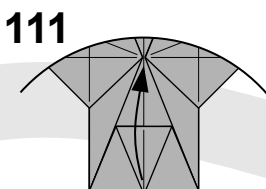

111

Unfold.

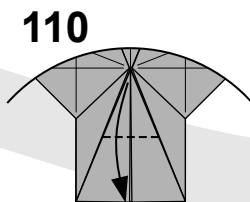

110

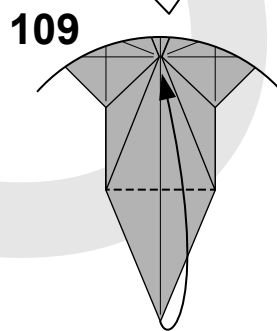

109

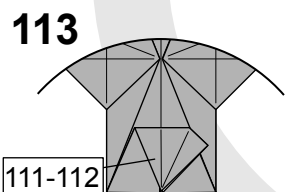

113

111-112

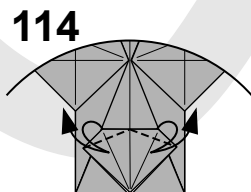

114

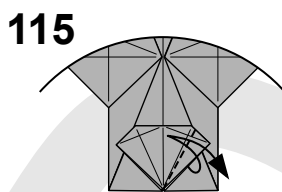

115

Fold and unfold, make a narrow wedge between the existing and new crease.

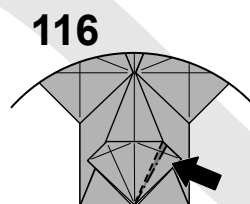

116

Carefully open sink the narrow wedge. Ensure the raw corner is still pointy.

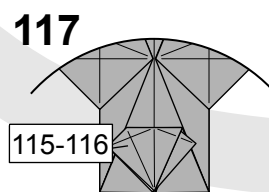

117

115-116

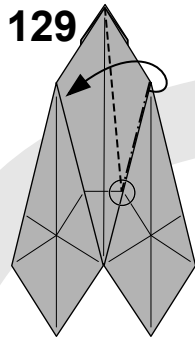

129 Make another 3D fold.

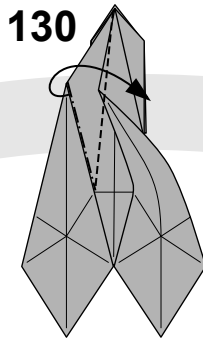

130 Repeat on the other side.

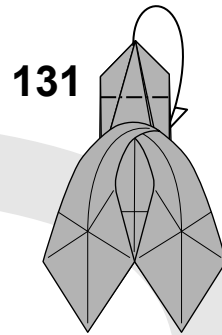

131 Mountain fold the thick flap in half.

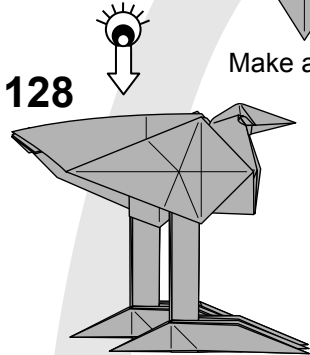

128 Change to top view.

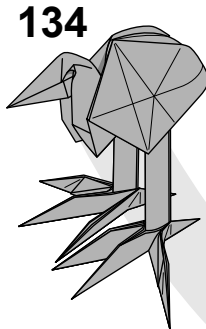

134 Spread the toes to finish the model.

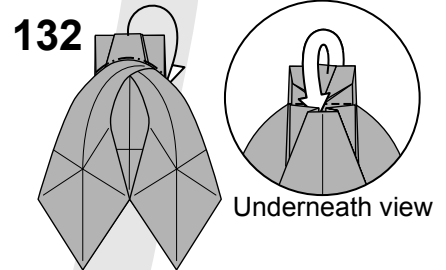

132 Mountain fold the thick folded edge at the base, tucking it inside a pocket underneath to lock the 3D body.

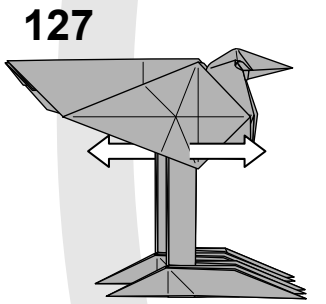

127 Slightly enlarge the gap between legs.

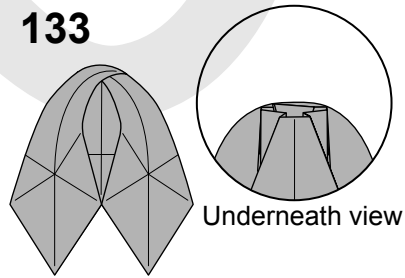

Underneath view

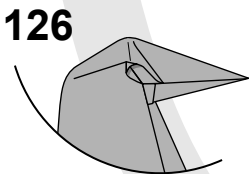

126 Pull the beak forward, while releasing some folds on top of the head.

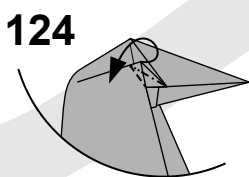

124 Squash, but keep the top part relatively unfolded to form eye. Repeat on the other side.

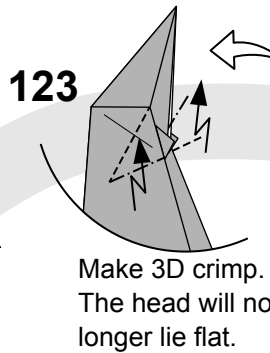

123 Make 3D crimp. The head will no longer lie flat.

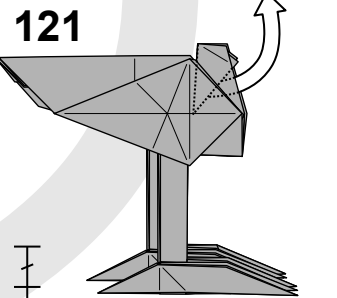
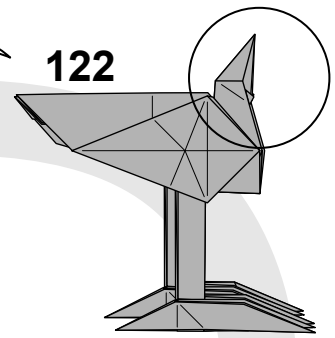

121 Raise the hidden corner underneath.

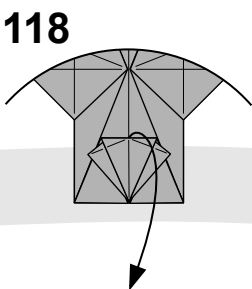

118

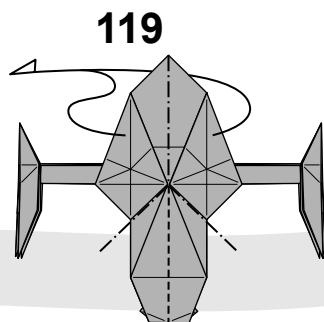

119 Rabbit ear.

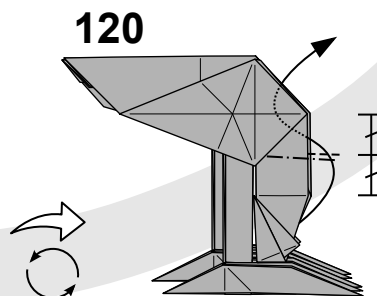

120 Inside reverse fold at approximately half of the edge.